

# Hines Driveline Build and Rebuild Equipment Fabrication and Balance Systems

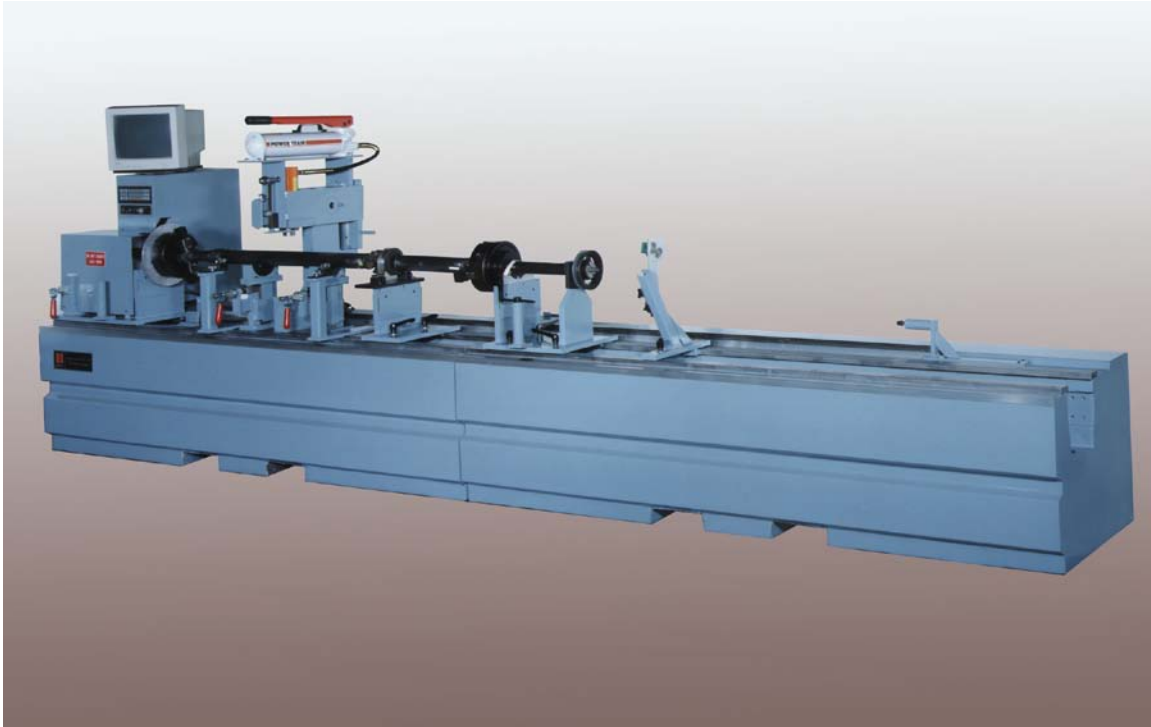

## Hines DL-500 Balancer with optional Straightening Press

### Why Should you Balance?

- Eliminates the premature failure of transmission seals.
- Eliminates the premature failure of differential seals.
- Eliminates premature failure of U-joints.
- Gives you smoother running, longer lasting drivetrains.
- Gives your customers higher quality products.
- Gives you the edge on your competition.

**BALANCE MEANS REPEAT BUSINESS AND HIGHER PROFITS!!!**

### The Hines Difference

- Hard suspension gives permanent calibration.
- Hines' runout sensors read the true centerline, not the irregular tube surface.
- The Hines computer tells you the exact amount and location of unbalance.
- The Hines balancer takes all the driveshaft components into consideration.
- The Four-jaw chucks eliminate costly changeover time.
- Designed and built from the ground up in Ann Arbor, Michigan.
- Design your own system with our variety of options.



**Driveline Computer**

## **Advanced Digital Computer Technology:**

- Unparalleled accuracy
- Easy Setup
- Quick Readout

**The computer walks the operator through every step!**



**DL-500 Machine**

## **Hines Balancer:**

- Rugged hard bearing suspension
- Simplified setup, first spin readout
- Factory calibration
- High sensitivity for precision
- Steel and formulated concrete base for vibration dampening and stability
- Balancers are our business

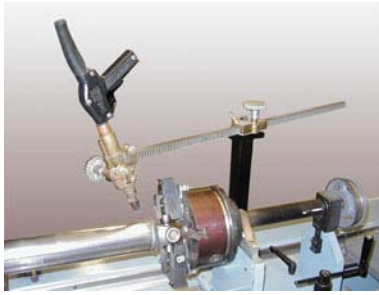
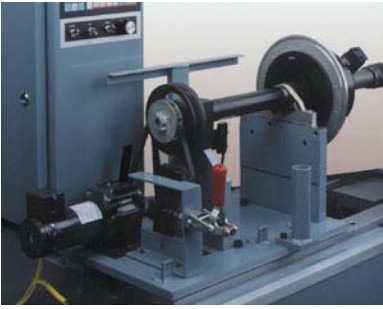

## **Welding Equipment:**

- An adjustable-speed motor control drives the spindle for the welding operation.
- Copper ground strap
- Gun holder

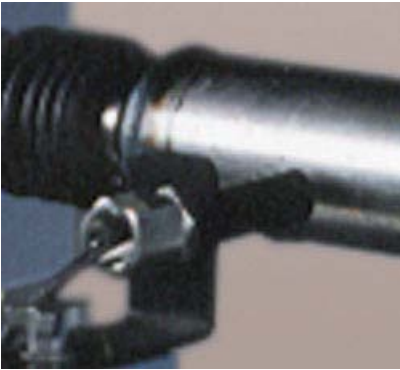

## **Runout Sensors:**

- Two non-contact runout sensors transfer runout signals to the computer.
- The computer filters out all tube irregularities to measure the actual amount and angle of tube runout—all in a matter of seconds!



## **Straightening Press System:**

- The press is a heavy-duty C-frame press with a two stage hydraulic pump.
- The Electronic Depth Sensor measures the amount of correction made by the press. This amount is displayed on the computer.

- Two Lift-Off Jacks with tooling correct runout before and after welding.



## Hines Tooling System:

The Four-Jaw Chucks are manufactured and balanced to precision tolerances. They hold the driveshaft on its true centerline providing outstanding accuracy. These chucks hold either couplings or tubing so the operator can balance through series 1810 driveshafts without changing tooling.



## **Balancer Options:**

- Standard and Heavy Duty Versions
- Wing Bearing Style and Other Tooling
- Special Wiring
- Adjustable Tolerance
- Second Center Stanchion
- Adjustable Bed Length
- Straightening Press

## **Balancer Specifications:**

Weight capacity	500 lbs.
Length	16 feet
Diameter (max inboard)	24 inches
Max. Sensitivity	+/- 0.02 oz/in
Workpiece Height (above floor)	36 inches
Base Size (2 beds)	16 ft. x 3 ft.
Floor Space Required	20 ft. x 7 ft.
Shipping Weight	8,000 lbs.
Machine Color	Blue-gray
Motor	1 hp, DC
Balancing Speed	500 rpm
Runout Speed	340 rpm

**Hines Industries, Inc.**

**793 Airport Blvd.**

**Ann Arbor, MI. 48108**

**Ph: (734) 769-2300 (ask for Automotive Aftermarket Sales)**

**FAX: (734) 996-9192 or visit us at <http://www.hinesindustries.com>**

**E-Mail: [Aftermarketsales@hinesindustries.com](mailto:Aftermarketsales@hinesindustries.com)**



## **The Hollow Spindle Tube Lathe**

**The Hines Hollow Spindle Tube Lathe allows you to cut and chamfer tubing with ease and efficiency. You can also use it to remove welds from existing shafts for replacement of tube shaft and yoke.**

**The lathe is made with a three-jaw chuck which expands to an inner diameter of 7-1/4 inches. This allows you to cut a variety of tubing sizes.**

**Variable speed control on the Hollow Spindle Tube Lathe makes matching end yokes and stub yokes easy!**

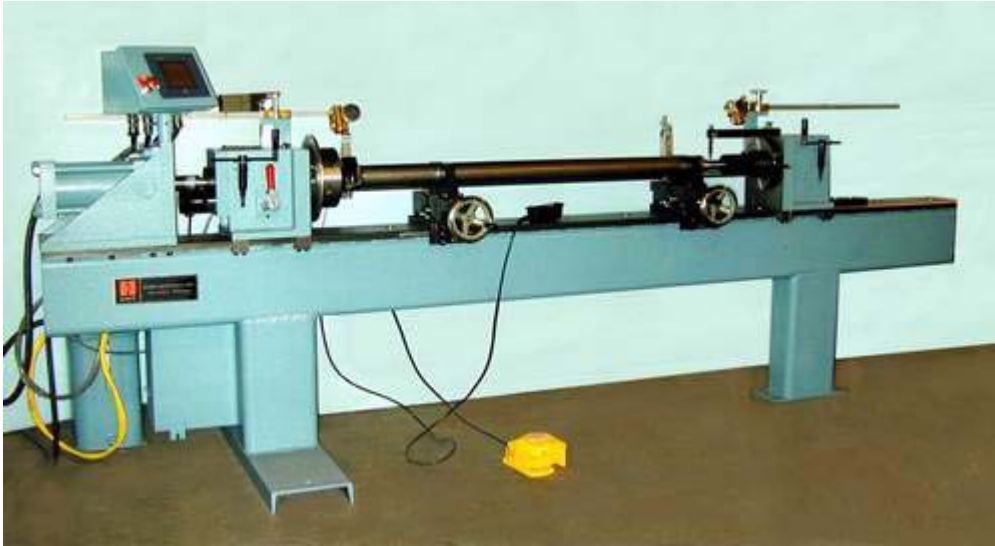

## **Hines Push-Up-Press P.S.W.S.** (Press, Straighten, Weld, Straighten )

The unit is designed to automate the building or rebuilding process of an automotive/truck driveshaft. The unit comes standard with two chucks, which have been modified to accept a u-joint. The operator will install the u-joint/yoke assembly into the chucks. The operator will then place the driveshaft tube into the machine aligning the tube ends with the yokes. The unit has two centering jaws that will hold the shaft centerline during the push up process, thus eliminating excessive run-out. Once the jaws are tightened, the shaft is ready to be pushed together. The operator can initiate the push up press process using a remote tether switch.

The shaft is now ready for initial straightening prior to welding the yoke or stub ends. The operator will release the centering jaws and initiate a run-out measurement. The unit is equipped with a PCL controller and two non-contact run-out indicators. The controller will determine (and display) shaft run-out based on one rotation of the shaft. It will then automatically index the shaft to the correct location for correction. Once correction is accomplished and verified the shaft ends are ready to be welded. Using a customer supplied welder, the operator will position the welding gun in a portable gun holder or in permanent welding racks. The operator will then select the proper welding rotation speed on the controller and initiate the shaft rotation via a foot peddle on the floor. There is a permanent welding ground attached to the machine. Upon completion of the welding process the operator will initiate a final run-out measurement. This will allow the operator to correct for any run-out created during the welding process. The shaft can now be removed and final balanced.

### **Additional Features:**

- The unit includes a spring-loaded center used to hold stub shafts. This would be used in place of a chuck.
- Unit includes a phasing locator pin, which ensures proper phasing of shaft ends.
- The unit includes center-bearing tooling used to install carrier bearings.
- The unit can push up new shafts or be used to repair existing shafts.

### **Specifications:**

**Power 220 Single Phase**

**Shipping Weight of unit 2000 lbs.**

**Size Capacity of Shaft (between chucks) 86 inches**

**Max Tube Diameter 6 inches**

**Pump Capacity 60,000 lbs.**



## **The Push-Up-Press**

**On the Hines Push-Up-Press, a 25 ton hydraulic ram simultaneously pushes a tight joint sub-assembly and a splined tube shaft into the tubing. This saves considerable labor time.**

**Stretched, heavy-duty, and high production models are available.**



## **The Push-Out-Press**

**With the Push-Out-Press you can remove end fittings from old or damaged driveshafts in one simple step. This machine can be used just as easily to remove center bearings.**

# Hines Driveline Build/Rebuild Equipment

**Enhance the flexibility of the Hines Driveline Balancer with Crankshaft Balancing Capability**

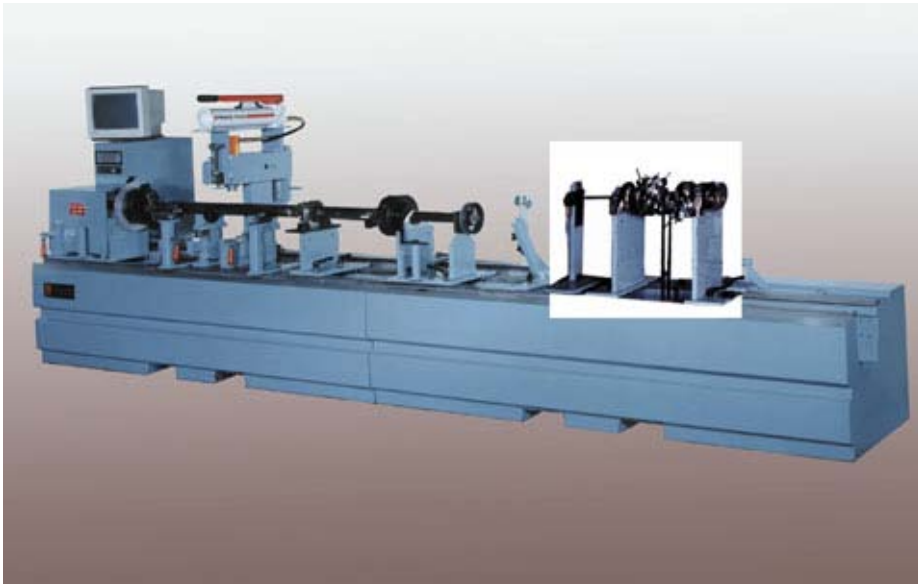

## **Option #A**

**The package includes an additional drive motor, encoder, stanchion assemblies, restraint bars and remote on/off switch. These items are mounted to the right 8 ft. base while sharing the advanced DL500 computer. This configuration allows an operator to balance one part at a time. Stanchion assemblies are portable allowing the right base to accommodate longer driveshafts. (see crankshaft brochure for balancing accessories).**

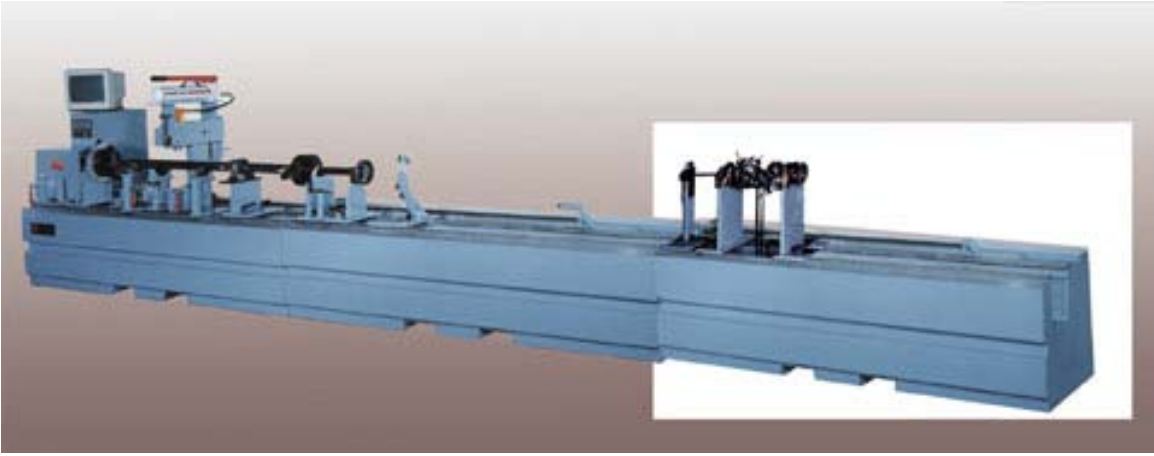

## **Option #B**

**The package includes an additional 8 ft. base, drive motor, encoder, stanchion assemblies, restraint bars and remote on/off switch. These items are mounted to the third 8 ft. base while sharing the advanced DL500 computer. This configuration reduces changeover time and increases shop efficiency. The operator is able to balance one part at a time. Stanchion assemblies are portable allowing the right base to accommodate longer shafts. (see crankshaft brochure for balancing accessories).**

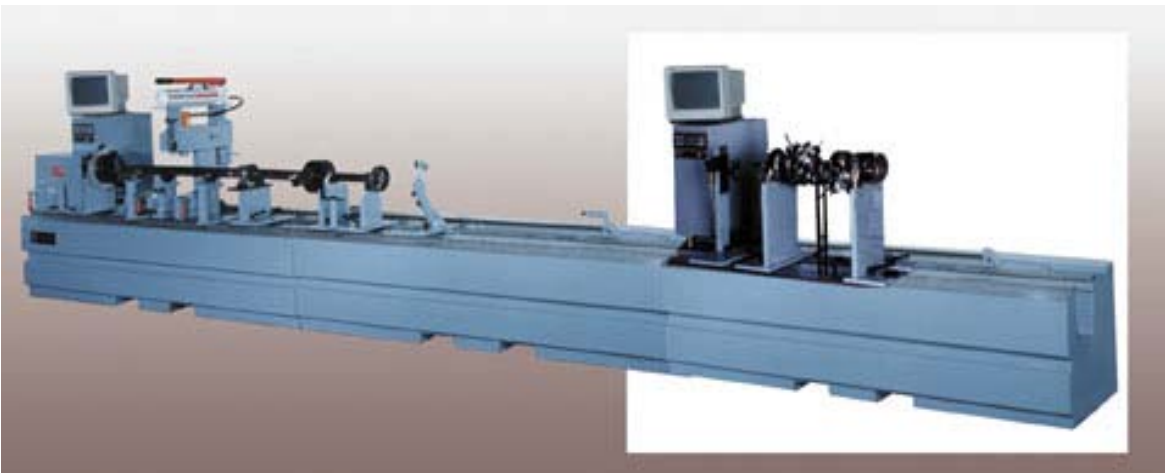

## **Option #C**

**This option allows balancing crankshafts and driveshafts simultaneously. The package includes an additional 8 ft. base, advanced computer with video display, drive motor, encoder, stanchion assemblies, restraint bars. The additional 8 ft. base reduces changeover time. Stanchion assemblies are portable allowing the third base to accommodate longer driveshafts. (see crankshaft brochure for balancing accessories).**